

PLAN

NOTES:

1. FRAME AND GRATE TO BE NYSDOT NO. 11 GALVANIZED WELDED FRAME (29"W x 37-1/2"L, O.D.) AND NYSDOT NO. 11 GALVANIZED RETICULINE GRATE (27-11/16"W x 36-1/2"L, O.D.) PER NYSDOT STANDARD SHEETS 624-01 AND 655-04.
2. CONCRETE CATCH BASIN SHALL BE NYSDOT TYPE S (24"W X 32"L, I.D.) PER NYSDOT STANDARD SHEET 604-02.
3. CONCRETE GUTTER SHALL BE 3000 PSI CONCRETE WITH 4"x4"-W2.9xW2.9 WELDED WIRE FABRIC.

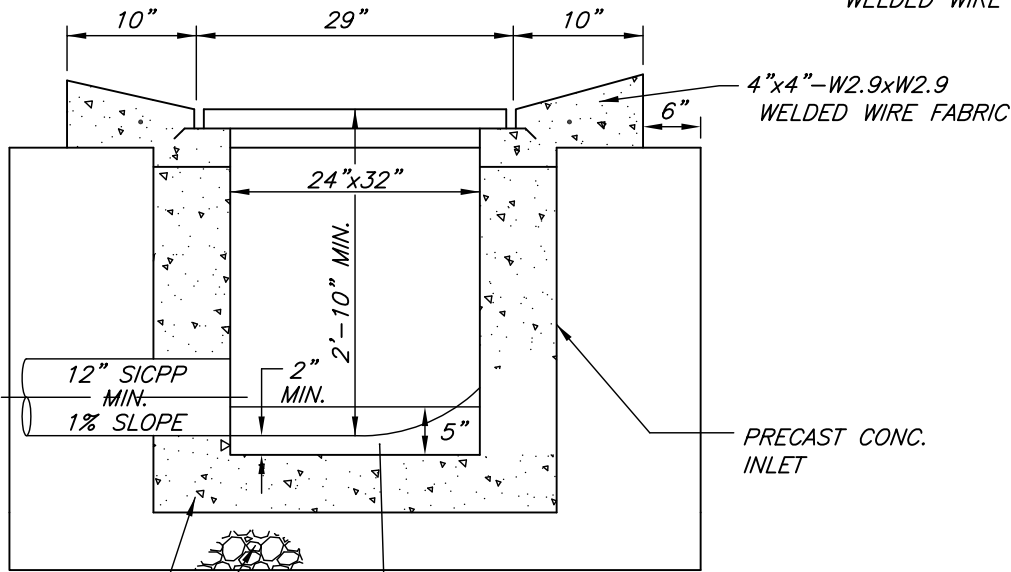

ELEVATION

**STANDARD GUTTER INLET**

N.T.S.

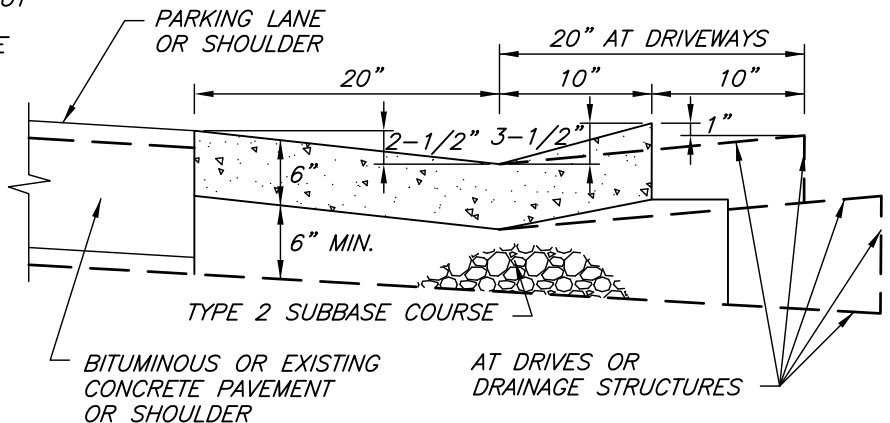

GUTTER SECTION

ISSUE DATE: OCTOBER 2013

REVISIONS		TOWN OF BATAVIA
DATE	COMMENTS	HIGHWAY & STORM SEWER DETAILS
		<h1>STANDARD GUTTER INLET</h1>