

SECTION A-A  
NOT TO SCALE

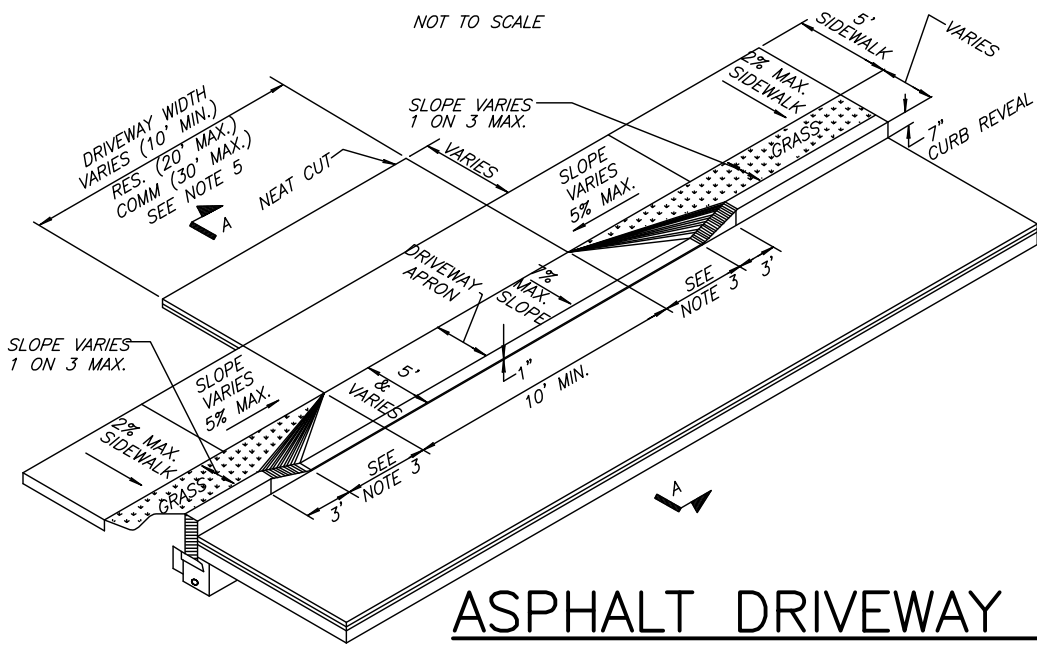

## ASPHALT DRIVEWAY APRON WITH SIDEWALK

N.T.S.

**NOTES:**

1. TOPSOIL AND SEED ALL DISTURBED AREAS WITH TOPSOIL ITEM NO. 613.0101 AND SEED ITEM NO. 601.0203.
2. EXPANSION JOINT MATERIAL TO BE PLACED A.O.B.E.
3. USE 5' FOR RESIDENTIAL, USE 10' MAX. OR A.O.B.E. FOR COMMERCIAL DRIVEWAYS AS REQUIRED FOR TRUCK TURNING/ACCESS.
4. WIDTH OF DRIVEWAY APRONS AT THE R.O.W. LINE SHALL MATCH EXISTING WIDTH.
5. IT IS DESIRABLE THAT DRIVEWAYS TO TOWN ROADS BE PAVED TO THE RIGHT-OF-WAY LINE. THE DRIVEWAY SHALL SLOPE AWAY FROM THE OUTSIDE EDGE OF THE SHOULDER AT A MINIMUM OF 4.0% TO THE CENTERLINE OF DRAINAGE.
6. REPLACE PAVEMENT IN KIND WITH WHAT IS EXISTING, UNLESS CONDITIONS EXIST WHERE THAT ISN'T FEASIBLE, THEN INSTALL SECTION AS APPROVED BY THE HIGHWAY SUPERINTENDENT. THE MINIMUM APPROVABLE SECTION SHALL BE 6" OF ITEM 301.12 TYPE 2 SUBBASE (CRUSHER RUN STONE). 2" OF ITEM 403.138902 TYPE 3 BINDER AND 1-1/2" OF ITEM 403.19802 TYPE 7F2 TOP.

ISSUE DATE: AUGUST 2012

REVISIONS		TOWN OF BATAVIA
DATE	COMMENTS	HIGHWAY & STORM SEWER DETAILS
		ASPH DWY APRON WITH SIDEWALK
		DRAWING HS-08